

CHROMA Q DIGITAL COMPONENT IDENTIFICATION DIAGRAM

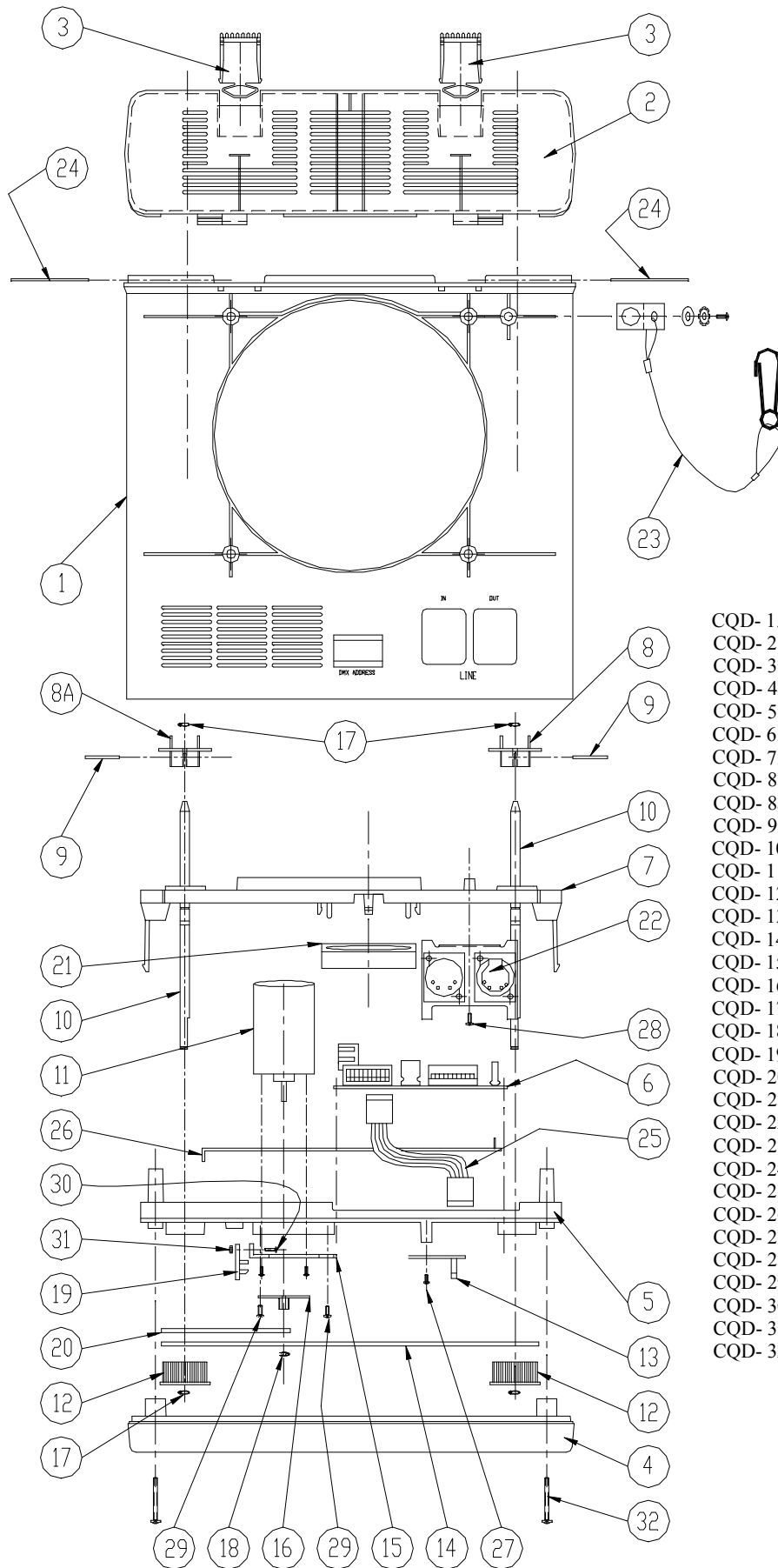

- CQD- 1. Chroma Q Body
- CQD- 2. Lid, no hinge, no latch.
- CQD- 3. Latches (2)
- CQD- 4. Base
- CQD- 5. Motor shelf with static plate & 2 bearings
- CQD- 6. Digital card Chroma Q MkII
- CQD- 7. Fan Shelf with 2 bearings
- CQD- 8. Drive wheel male (grey)
- CQD- 8a. Drive wheel male (black)
- CQD- 9. Spring pins 3/32 x 1/2 (2)
- CQD- 10. Shaft Drive/Driven
- CQD- 11. Mabuchi Motor with leads and chokes
- CQD- 12. Timing pulley (2)
- CQD- 13. LED card
- CQD- 14. Large belt 4T25-540
- CQD- 15. Motor adjustment bracket
- CQD- 16. Motor gear /Opto Wheel
- CQD- 17. Circlip(s) for shaft 6mm (4)
- CQD- 18. E Clip for motor shaft
- CQD- 19. Opto encoder assembly (2)
- CQD- 20. Small belt 4T25-200
- CQD- 21. Jamicon 12v 40mm fan assembly
- CQD- 22. XLR assembly M/F/plate/leads
- CQD- 23. Safety chain Assembly Kit
- CQD- 24. Hinge pin for lid (2)
- CQD- 25. 4 wire LED assembly
- CQD- 26. Static plate
- CQD- 27. M3 x 6 Plastite (2)
- CQD- 28. M3.5 x 10 Plastite
- CQD- 29. M3 x 10 screw (3)
- CQD- 30. M3 x 8 screw (2)
- CQD- 31. M3 hex nut plain (2)
- CQD- 32. M4 x 60 screw (4)

CHROMA Q DIGITAL COMPONENT IDENTIFICATION DIAGRAM
REMOVABLE TAKE UP REELS

